

HYDAC

INTERNATIONAL

Tank Breather Filter

ELF/BF/BL/BLT/LU
Drymicron

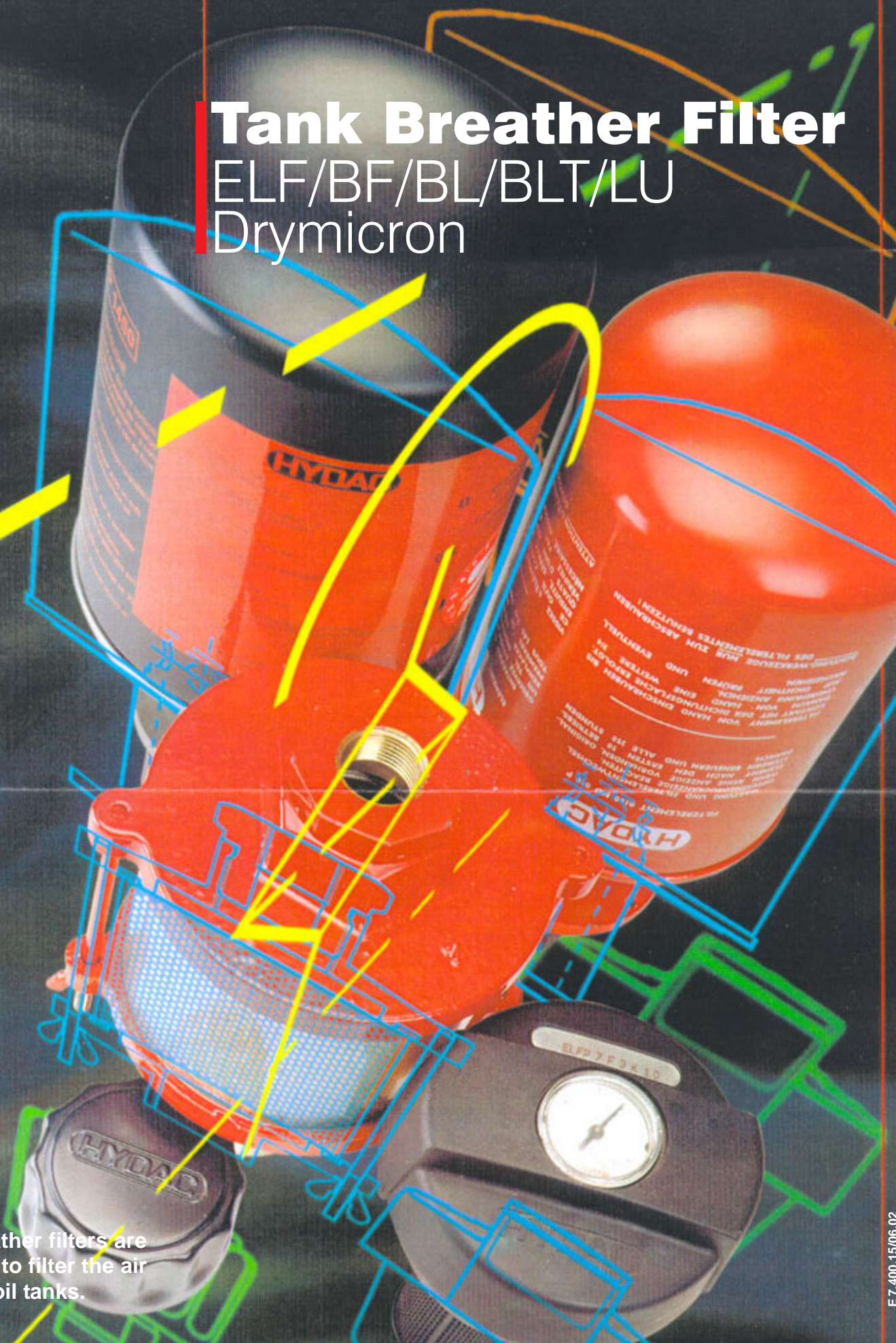

Tank breather filters are designed to filter the air entering oil tanks.

INDEX	Page:
1. FILTERS	2 - 15
1.1. ELF	2
1.2. BF	6
1.3. BL	10
1.4. BLT	13
2. ADAPTORS	16
3. GENERAL	17
4. FILTER SIZING	18
5. BREATHER/DRYER	19
6. DEHUMIDIFIERS	22

1. FILTERS

1.1. ELF
(TANK BREATHER FILTER WITH FILLER STRAINER)

1.1.1. Technical description

1.1.1.1 Filter housing

Construction

Tank breather filters size 3 and 4 consist of an air filter top, which is connected to the mounting flange by a bayonet plate, and a filler strainer.

The top is attached by a chain to prevent loss.

Size 5 and 52 consist of a two-part threaded air filter top, with one or two exchangeable filter element(s) and a filler strainer.

Size 7 consists of a two-part flanged filter top, an exchangeable filter element and a filler strainer.

1.1.1.2 Filter elements

Hydac filter elements fulfil all ISO test criteria.

Reliable filter operation is only guaranteed for original Hydac filter elements.

The filter elements are made from phenolic resin impregnated paper and cannot therefore be cleaned.

Fluid compatibility

The standard models are suitable for use with mineral and lubrication oils. For use with non-flam and rapidly biodegradable fluids, please see table:

Non-flam fluids			
Size	HFA	HFC	HFD-R
3	–	–	–
4	–	–	–
5	●	●	–
52	●	●	–
7	●	●	–

Rapidly biodegradable fluids				
Size	HTG	HE	HPG	
			PAG	PEG
3	+	+	●	●
4	+	+	●	●
5	+	+	●	●
52	+	+	●	●
7	+	+	●	●

+ unlimited suitability

– not suitable

● limited suitability

HFA oil in water emulsion
(H₂O content ≥ 80%)

HFC water polyglycol solution
(H₂O content 35-55%)

HFD-R synthetic, water-free phosphate ester

HTG vegetable oil based hydraulic fluids

HE ester-based synthetic hydraulic fluids

HPG polyglycol-based synthetic hydraulic fluids

PAG sub-group HPG:
polyalkylene glycol

PEG sub-group HPG:
polyethylene glycol

1.1.1.3 Seals

Perbunan (= NBR) on the bayonet plate

Polyurethane on the element

Cardboard on the mounting flange

1.1.1.4 Special models and accessories

– Filter type ELF 3 lockable model

– Filter type ELF 3 with a check/bypass valve for improved pump suction

– Metal filler strainer available for filter types ELF 3 and 7

– Clogging indicators for filter type ELF 7

– Filler adaptor for filter types ELF 3, ELFL 3, ELF 7 (see point 2, page 16)

1.1.2. General

Temperature range

-30 °C to +100 °C

Weights

ELF 3 0.25 kg

ELF 3 /-RV 0.30 kg

ELF 4 0.20 kg

ELF 5..2.0 2.70 kg

ELF 5..3.0 3.10 kg

ELF 5..4.0 2.70 kg

ELF 5..5.0 2.60 kg

ELF 52..2.0 3.10 kg

ELF 7 0.38 kg

Symbol

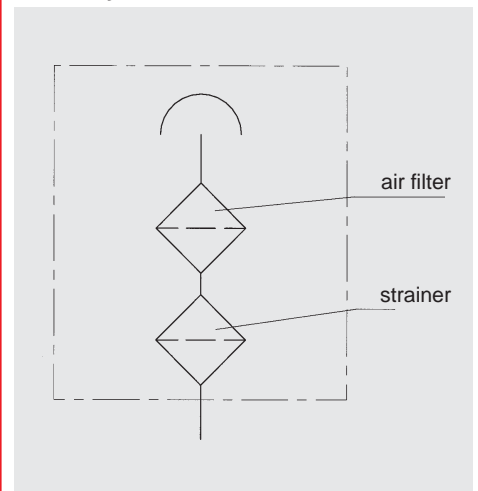

Changing intervals

The breather filter elements or filters must be replaced as frequently as the fluid filters, but at least once per year.

1.1.3. Model code (also order example)

ELF P 3 F 10 W 1. X /-RV

1.1.3.1 Complete filter

Filter type

ELF
ELFL (lockable)

Filter material

P paper

Size

3 (housing: steel, zinc-plated / synthetic coating; filler strainer: synthetic material)

4 (housing: steel, zinc-plated / synthetic coating; filler strainer: synthetic material)

5, 52 (housing: steel; filler strainer: metal)

7 (housing: glass fibre reinforced synthetic material; filler strainer: synthetic material)

Type of connection

Type	Filter size				
	ELF 3	ELF 4	ELF 5	ELF 52	ELF 7
F	●	●			●
G 1 ½			●	●	
G 2			●	●	
G 2 ½			●	●	
G 3			●	●	

G = threaded connection to ISO 228

F = flange connection (interface to DIN 24557/Part 2)

Filtration rating in µm

3 = 3µm absolute

10 = 10µm absolute

Type of clogging indicator

W = no port for clogging indicator

K = pressure gauge, measuring range -1 to +0.6 bar (only for ELF 7)

Type code

	G	F	Δp [bar]
ELF 3...1.0		●	
ELF 3...4.0 /-RV		●	0.4
ELF 3...5.0 /-RV		●	0.7
ELF 3...6.0 /-RV		●	0.2
ELF 3...7.0 /-RV		●	1.0
ELF 4...1.0		●	
ELF 5(2)...2.0	G 2 ½		
ELF 5(2)...3.0	G 3		
ELF 5(2)...4.0	G 2		
ELF 5(2)...5.0	G 1 ½		
ELF 7...1.0		●	

Modification number

X the latest version is always supplied

Supplementary details

-AS anti-splash (only ELF 3, ELF 7)

-RV check/bypass valve (only ELF 3), not 100% air-tight or leakage-free

-SO148 metal filler strainer, 200 mm long (only ELF 3, ELF 7)

-SO175 metal filler strainer, 100 mm long (only ELF 3, ELF 7)

1.1.3.2 Replacement element

0005 L 010 P

Size

0005 (for ELF 5 and 52)

0007 (for ELF 7)

Type

L for air filter element

Filtration rating in µm

003 3µm absolute

010 10µm absolute

Filter material

P paper (absolute filtration)

Replacement element not available for size 3 and 4

1.1.4. Dimensions ELF

ELF 3 F..., ELF 3 F... /-RV

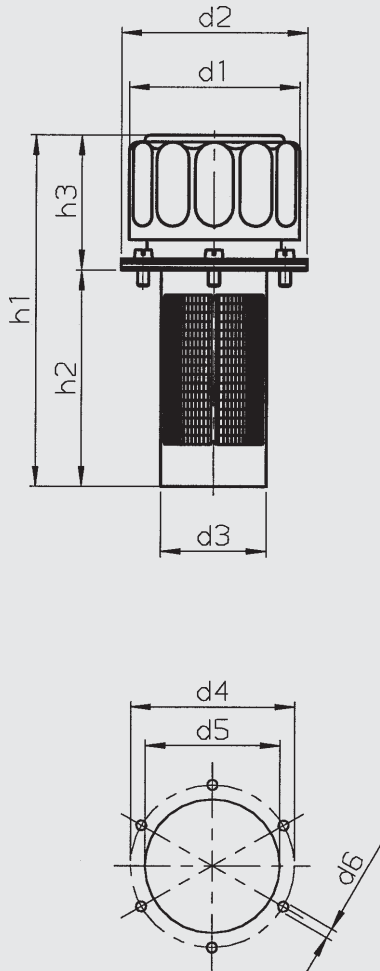

Interface to DIN 24557/Part 2

Type	ELF 3 F...	ELF 3 F.../-RV
d1	76	76
d2	83	83
d3	49	49
d4	73	73
d5	60	60
d6	4.5	4.5
h1	159	159
h2	96.5	96.5
h3	62.5	62.5

ELFL 3 F...

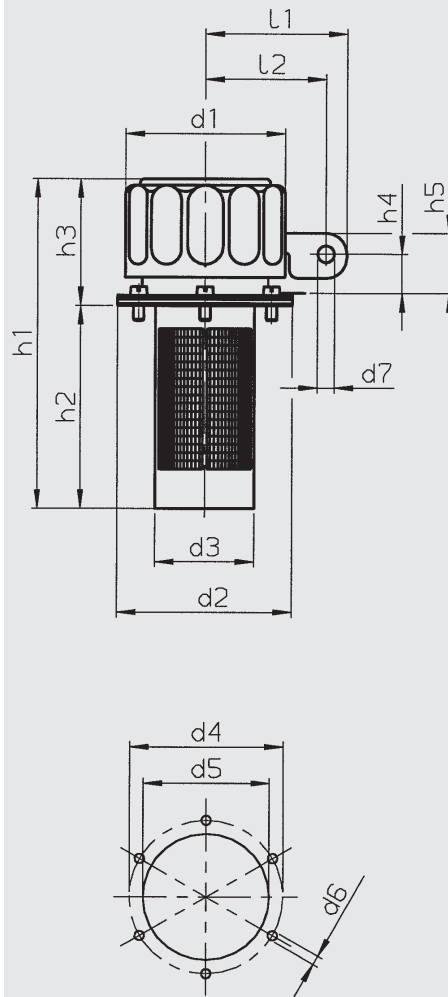

Interface to DIN 24557/Part 2

Type	ELFL 3 F...
d1	76
d2	83
d3	49
d4	73
d5	60
d6	4.5
d7	8
h1	159
h2	96.5
h3	62.5
h4	21
h5	31
l1	67.5
l2	57.5

ELF 4 F...

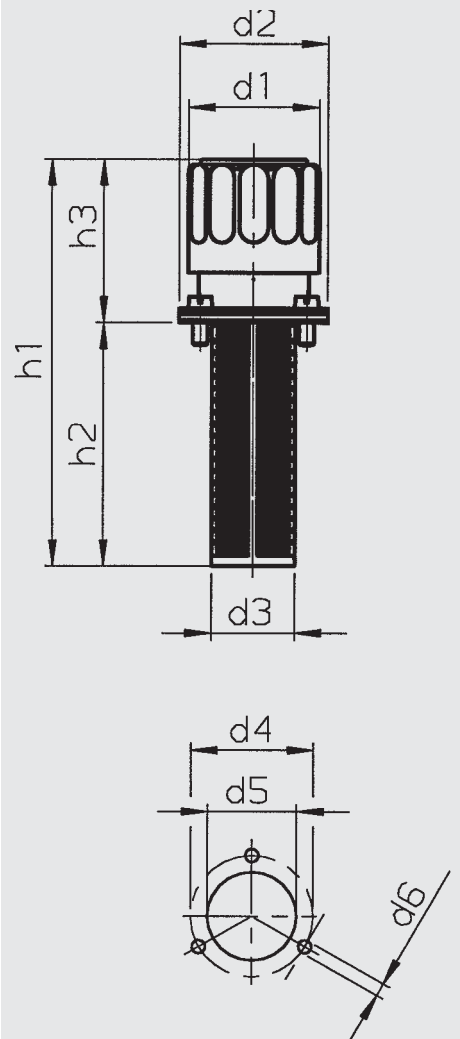

Type	ELF 4 G...
d1	44
d2	50
d3	28
d4	41.3
d5	30
d6	4.5
h1	135
h2	81.5
h3	53.5

ELF 5 G...

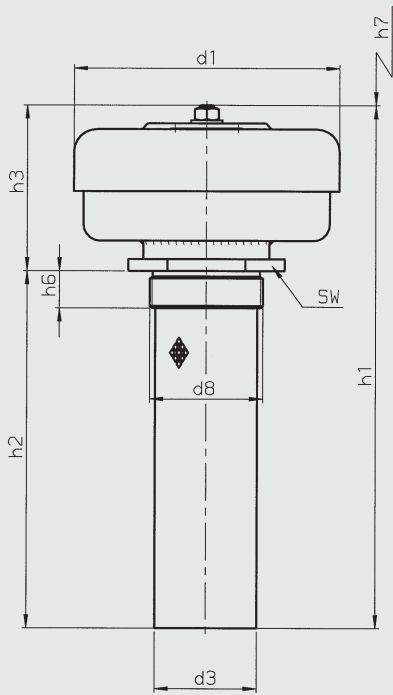

Type	ELF 5 G..2.0	ELF 5 G..3.0
d1	177	177
d3	68	68
d8	G2 ½ ISO 228	G3 ISO 228
h1	350	350
h2	240	240
h3	105	105
h6	25	25
h7	90	90
SW	90	90

Type	ELF5G..4.0	ELF5G..5.0
d1	177	177
d3	49.5	39.5
d8	G2 ISO 228	G1 ½ ISO 228
h1	350	350
h2	240	240
h3	105	105
h6	25	25
h7	90	90
SW	90	90

ELF 52 G...

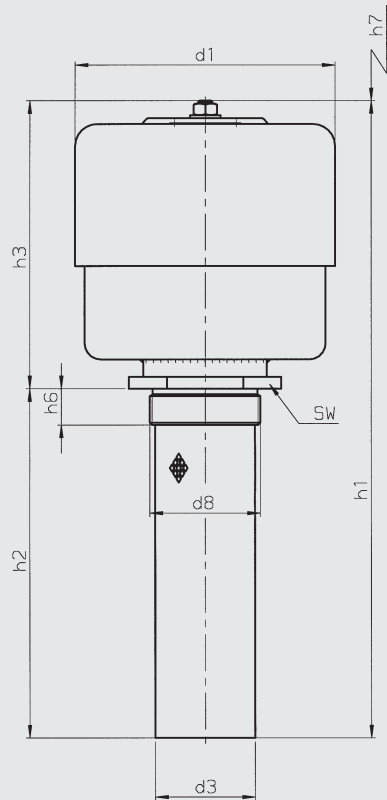

Type	ELF 52 G..2.0
d1	177
d3	68
d8	G2 ½ ISO 228
h1	416
h2	240
h3	176
h6	25
h7	90
SW	90

ELF 7 F...

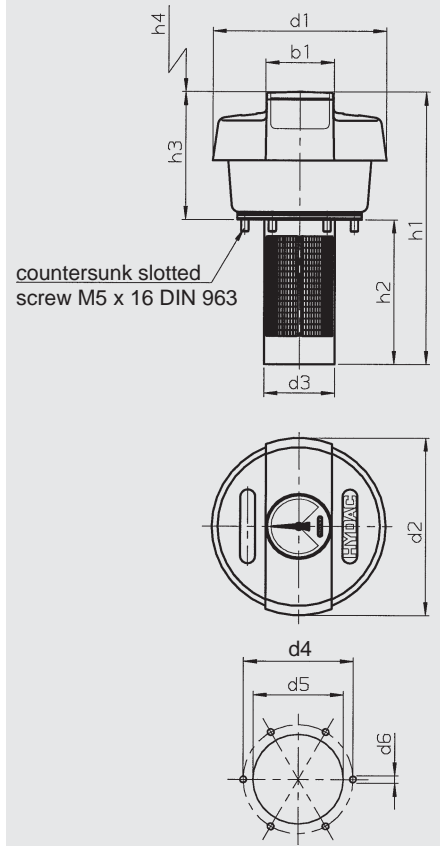

Interface to DIN 24557/Part 2

Type	ELF 7 F..
d1	116
d2	120
d3	49
d4	73
d5	60
d6	M5
h1	181
h2	97
h3	84
h4	60
b1	44

1.2. BF (TANK BREATHER FILTER)

1.2.1. Technical description

1.2.1.1 Filter housing

Construction

Tank breather filters size 3 and 4 consist of a housing that can be screwed on to the oil tank, and a built-in filter element.

Note:

When filters are fitted or removed they must only be tightened or unscrewed at the hexagonal nut.

Sizes 5, 52 and 7 have housings that can be screwed onto the tank and have one or two exchangeable filter element(s).

Size 8 consists of a flange for mounting to the tank, an exchangeable element and a cap.

1.2.1.2 Filter elements

Hydac filter elements fulfil all ISO test criteria.

Reliable filter operation is only guaranteed for original Hydac filter elements.

The filter elements are made from phenolic resin impregnated paper or from inorganic fibre (only for BF 8) and cannot therefore be cleaned.

Fluid compatibility

The standard models are suitable for use with mineral and lubrication oils. For use with non-flam and rapidly biodegradable fluids, please see table:

Non-flam fluids			
Size	HFA	HFC	HFD-R
3	–	–	–
4	–	–	–
5	●	●	–
52	●	●	–
7	●	●	–
8	●	●	●

Rapidly biodegradable fluids				
Size	HTG	HE	HPG PAG	PEG
3	+	+	●	●
4	+	+	●	●
5	+	+	●	●
52	+	+	●	●
7	+	+	●	●
8	+	+	●	●

- + unlimited suitability
- not suitable
- limited suitability

HFA oil in water emulsion (H₂O content ≥ 80%)

HFC water polyglycol solution (H₂O content 35-55%)

HFD-R synthetic, water-free phosphate ester

HTG vegetable oil based hydraulic fluids

HE ester-based synthetic hydraulic fluids

HPG polyglycol-based synthetic hydraulic fluids

PAG sub-group HPG: polyalkylene glycol

PEG sub-group HPG: polyethylene glycol

1.2.1.3 Seals

Polyurethane on the element

1.2.1.4 Special models and accessories

– Filter type BF 3 with a check/bypass valve for improved pump suction

– Clogging indicators for filter type BF 7 and BF 8

– Tamper proof BF 3 (-DS)

1.2.2. General

Temperature range

-30 °C to +100 °C

Weights

BF 3./-RV	0.38 kg
BF 3	0.33 kg
BF 4	0.08 kg
BF 5	2.00 kg
BF 52	2.60 kg
BF 7	0.40 kg
BF 8	12.4 kg

Symbol

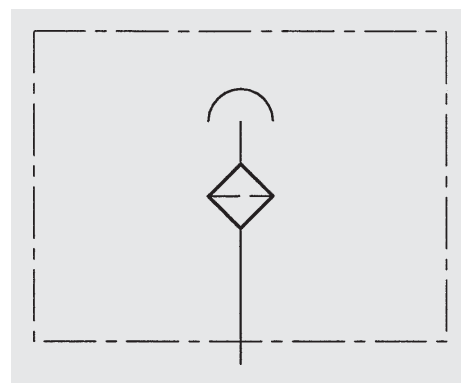

Changing intervals

The breather filter elements or filters must be replaced as frequently as the fluid filters, but at least once per year.

1.2.3. Model code (also order example)

BF P 3 F 10 W 1. X /-RV

1.2.3.1 Complete filter

Filter type

BF

Filter material

BN (only BF 8)

BN/AM (only BF 8)

P

Size

3 (housing: steel, zinc-plated / synthetic coating)

4 (housing: steel, zinc-plated / synthetic coating)

5 (housing: steel)

7 (housing: glass fibre reinforced synthetic material)

8 (housing: steel, galvanised)

Type of connection

Type	Filter size					
	BF 3	BF 4	BF 5	BF 52	BF 7	BF 8
F						●
G ¼		●				
G ½	●					
G ¾	●					
G 3/8	●					
G 1					●	
G 2 ½			●	●		

G = threaded connection to ISO 228

F = flange connection

Filtration rating in µm

10 = 1µm absolute (for BN, BN/AM, only for BF 8)

3 = 3µm absolute (for P)

10 = 10µm absolute (for P)

Type of clogging indicator

W = no port for clogging indicator

K = pressure gauge, measuring range -1 to +0.6 bar (only for BF 7 and BF 8)

Type code

	G	F	Δp [bar]
BF 3...1.0	G ¼		
BF 3...2.0	G 3/8		
BF 3...3.0	G ½		
BF 3...4.0 /-RV	G ¾		0.4
BF 3...5.0 /-RV	G ¾		0.7
BF 3...6.0 /-RV	G ¾		0.2
BF 3...7.0 /-RV	G ¾		1.0
BF 4...1.0	G ¼		
BF 5...1.0	G 2 ½		
BF 52...1.0	G 2 ½		
BF 7...1.0	G 1		
BF 8...1.0		●	

Modification number

X the latest version is always supplied

Supplementary details

RV check/bypass valve (only BF 3), not 100% air-tight or leakage-free

DS tamper proof (for BF 3 only)

1.2.3.2 Replacement element

0005 L 010 P

Size

0005 (for BF 5 and 52)

0007 (for BF 7)

0008 (for BF 8)

Type

L for air filter element

Filtration rating in µm

003

010

Filter material

P paper (for BF 5, 52 and 7)

BN Betamicron® (for BF 8)

Replacement element not available for size 3 and 4

1.2.4. Dimensions BF

BF 3 G..., BF 3 G.../-RV

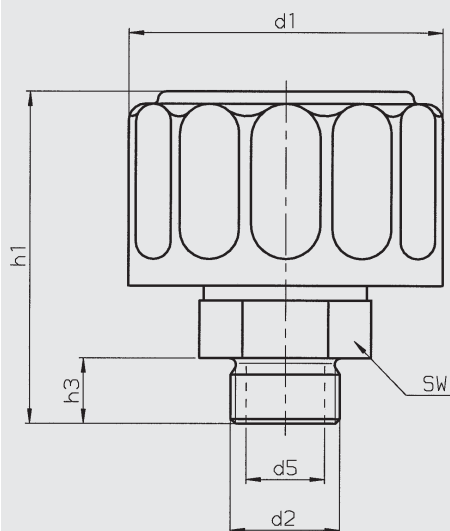

Type	BF 3G..1.0 BF 3G.. /-RV	BF 3G..2.0
d1	76	76
d2	G ¾ ISO 228	G 3/8 ISO 228
d5	19	12
h1	79	72
h3	16	12
SW	36	22

Type	BF 3G..3.0
d1	76
d2	G ½ ISO 228
d5	15
h1	76
h3	14
SW	27

BF 4 G...

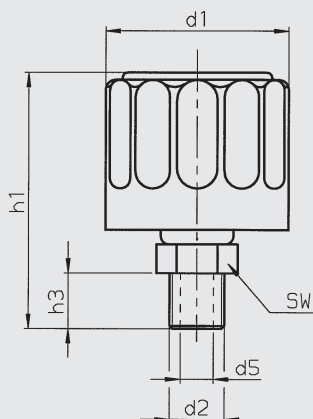

Type	BF 4 G... 1.0
d1	44
d2	G ¼ ISO 228
d5	8
h1	62
h3	13,5
SW	17

BF 5 G...

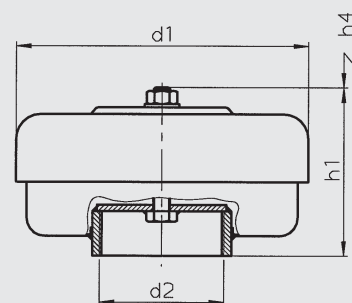

Type	BF 5G..1.0
d1	177
d2	G2 ½ ISO 228
h1	107
h4	90

BF 52 G...

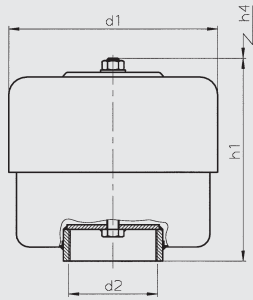

Type	BF 52 G...
d1	177
d2	G2 ½ ISO 228
h1	173
h4	90

BF 7 G...

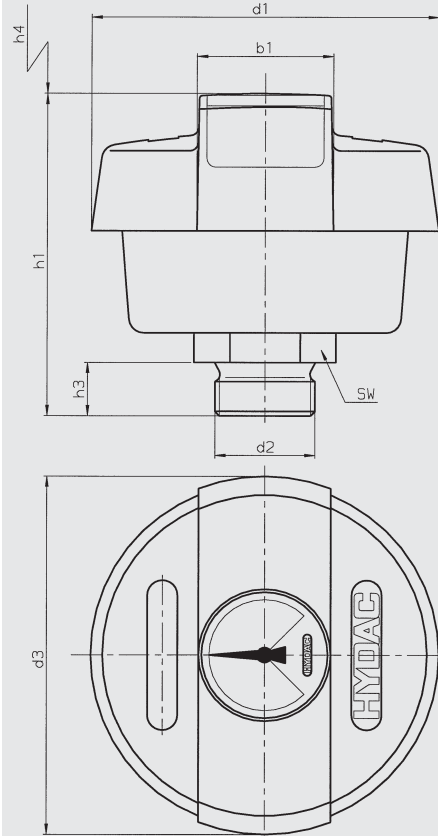

Type	BF 7 G...
d1	116
d2	G1 ISO 228
d3	120
h1	110
h3	18
h4	60
b1	44
SW	41

BF 8 F...

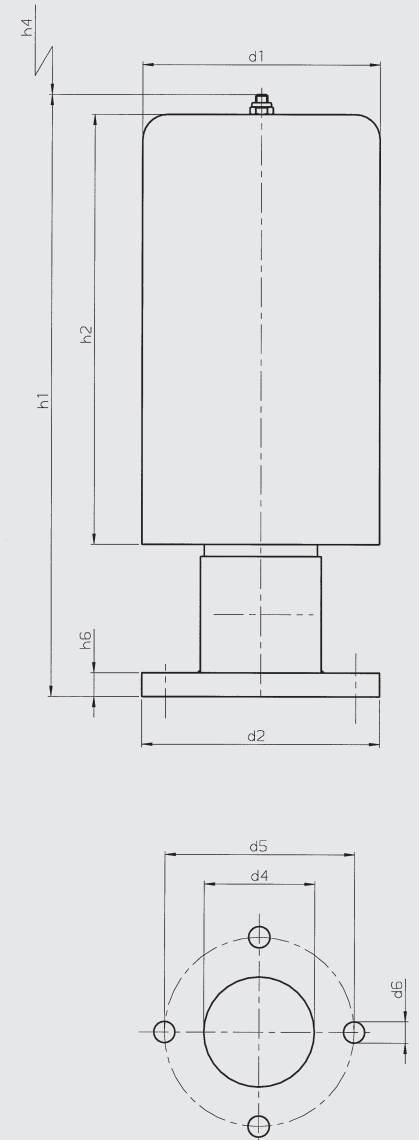

Interface BF 8 F...

Type	BF 8 F...
d1	200
d2	200
d4	93
d5	160
d6	18
h1	510
h2	365
h4	400
h6	20

1.3. BL
(TANK BREATHER FILTER WITH
SPIN-ON FILTER CAN)

1.3.1. **Technical description**

1.3.1.1 Filter housing

Construction

Tank breather filters consist of a spin-on filter can which screws onto a connection tube which is fitted to the oil tank.

In order to comply with the requirements of the French automobile industry (CNOMO), BL filters can be fitted to an adaptor block to enable filling of oil via an off-line filtration unit. The connection can be either flanged or welded.

1.3.1.2 Filter elements

Hydac filter elements fulfil all ISO test criteria

Reliable filter operation is only guaranteed for original Hydac filter elements.

The filter elements are made from phenolic resin impregnated paper or from inorganic fibre and cannot therefore be cleaned.

Fluid compatibility

The standard models are suitable for use with mineral and lubrication oils. For use with non-flam and rapidly biodegradable fluids, please see table:

Non-flam fluids			
Size	HFA	HFC	HFD-R
40	–	–	–
82	–	–	–
162	●	●	–

Rapidly biodegradable fluids				
Size	HTG	HE	HPG	
			PAG	PEG
40	+	+	●	●
82	+	+	●	●
162	+	+	●	●

- + unlimited suitability
- not suitable
- limited suitability

- HFA oil in water emulsion (H₂O content ≥ 80%)
- HFC water polyglycol solution (H₂O content 35-55%)
- HFD-R synthetic, water-free phosphate ester
- HTG vegetable oil based hydraulic fluids
- HE ester-based synthetic hydraulic fluids
- HPG polyglycol-based synthetic hydraulic fluids
- PAG sub-group HPG: polyalkylene glycol
- PEG sub-group HPG: polyethylene glycol

1.3.1.3 Seals

Perbunan (=NBR)

1.3.1.4 Special models and accessories

- Filler adaptor for filter type BL 162...F (see point 2, page 16)
- With port for clogging indicator

1.3.2. **General**

Temperature range

-30°C to +100°C

Weights

BL 40 S...	0.78 kg
BL 82 S...	0.95 kg
BL 162 F...	2.10 kg
BL 162 S...	1.75 kg

Symbol

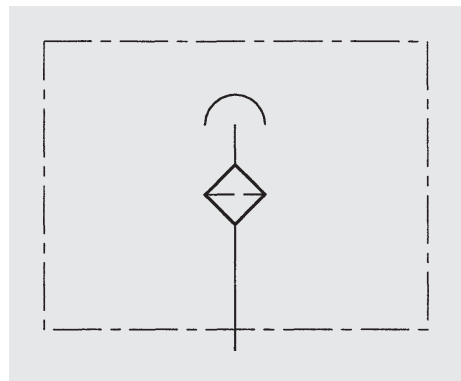

1.3.3. **Model codes for French automobile industry**

Standard	Filter Type	Element
CNOMO 1	BL P 40 S 3 W 1.0	BF P 3 G 3 W 1.0
CNOMO 2	BL BN 82 S 20 W 1.0	0080 MG 020 BN
CNOMO 3	BL BN 162 S 20 W 2.0	0160 MA 020 BN

Changing intervals

The breather filter elements or filters must be replaced as frequently as the fluid filters, but at least once per year.

1.3.4. Model code (also order example)

BL P 40 S 10 W 1. X

1.3.4.1 Complete filter

Filter type _____

BL

Filter material _____

BN

P

Size _____

40

82 (connection tube: steel; spin-on can: sheet metal)

162

Type of connection _____

Type	Filter size		
	BL 40	BL 82	BL 162
F		●	●
S	●	●	●

F = flange connection
S = weld connection

Filtration rating in μm _____

10 = 1 μm absolute (for BN)

20 = 2 μm absolute (for BN)

3 = 3 μm absolute (for P, only for BL 40)

10 = 10 μm absolute (for P)

Type of clogging indicator _____

W = no port for clogging indicator

Type code _____

1. = for sizes 40, 82

2. = for size 162

Modification number _____

X the latest version is always supplied

1.3.4.2 Replacement element for size 82 and 162

0160 MU 010 P

Size _____

0080

0160

Type _____

MA (only for BL BN 162)

MU (only for BL P 162...)

MG (only for BL 82...)

Filtration rating in μm _____

BN 010, 020

P 010

Filter material _____

BN Betamicron®

P paper

1.3.4.3 Replacement filter for size 40

BF P 3 G 3 W 1.0 (for filtration rating 3 μm)

BF P 3 G 10 W 1.0 (for filtration rating 10 μm)

1.3.5. Dimensions BL

BL 40 S..

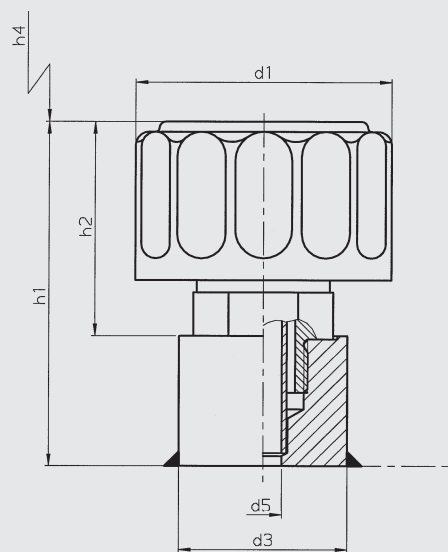

Type	BL 40 S..
d1	76
d3	50
d5	13
h1	102
h2	63
h4	20

BL 82 S.., BL 162 S..

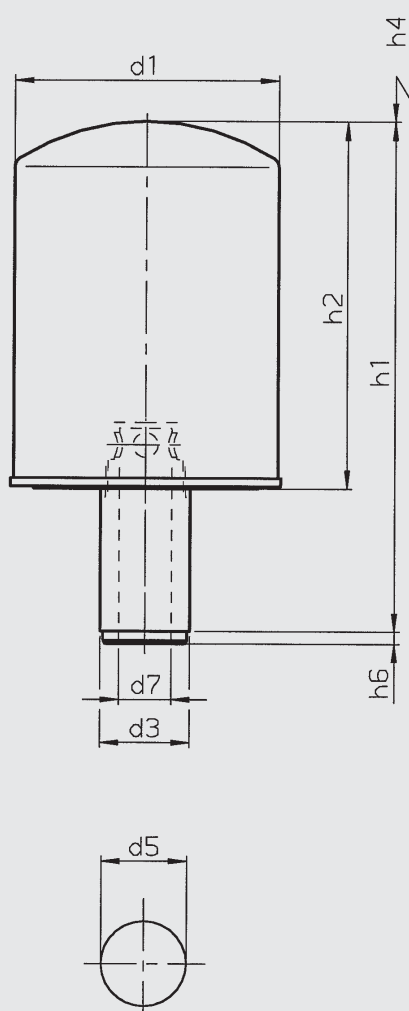

Interface BL 82 S and BL 162 S

Type	BL 82 S..	BL 162 S..
d1	98	127
d3	27	43
d5	25	41
d7	16	25
h1	186	245
h2	142	175
h4	90	90
h6	6	6

BL 82 F., BL 162 F..

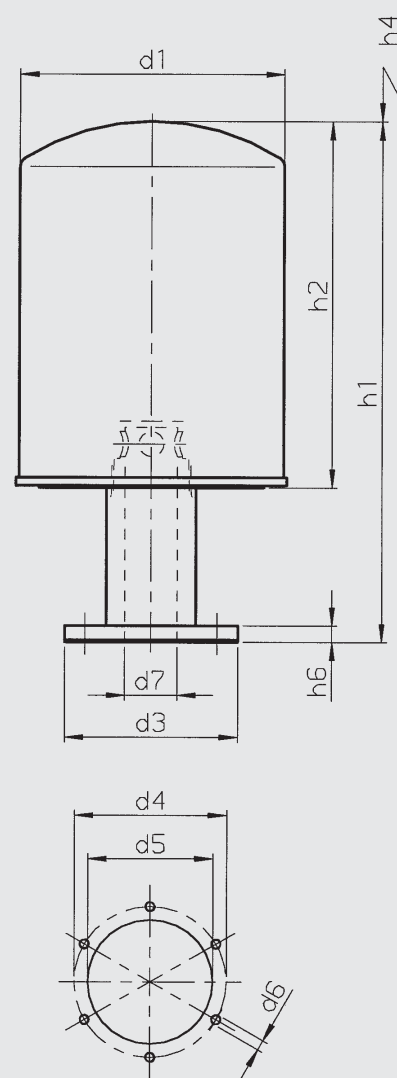

Interface to DIN 24557/Part 2

Type	BL 82 F..	BL 162 F..
d1	98	127
d3	80	80
d4	73	73
d5	60	60
d6	M5	M5
d7	16	25
h1	227	260
h2	142	175
h4	90	90
h6	7	7

1.4. BLT
(BREATHER FILTER AND
DEHUMIDIFIER)

1.4.1. **Technical description**

1.4.1.1 Filter housing

Construction

The BLT filter consists of a spin-on filter can which screws onto a connection tube which is fitted to the oil tank.

The connection can be either flanged or welded.

1.4.1.2 Filter elements

Hydac filter elements fulfil all ISO test criteria.

Reliable filter operation is only guaranteed for original Hydac filter elements.

Fluid compatibility

The standard models are suitable for use with mineral and lubrication oils. The BLT is suitable for use with all oils used in hydraulics.

1.4.1.3 Seals

Perbunan (=NBR)

1.4.1.4 Special models and accessories

– on request

1.4.2. **General**

Temperature range

-30 °C to +100 °C

Maintenance intervals

Every 6 months

Weights

BLT 160 2.40 kg

Water retention capacity

Temperature	Rel. humidity	g H ₂ O
0 °C	30%	190
15 °C	60%	210
25 °C	90%	230

Symbol

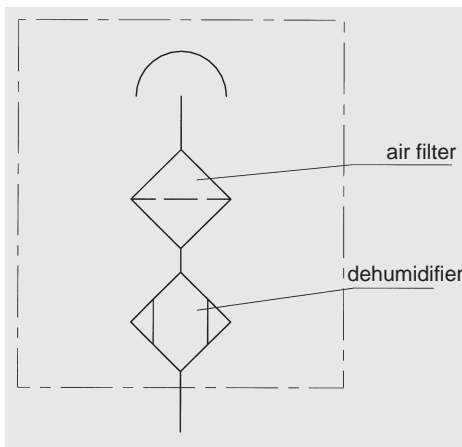

Changing intervals

The breather filter elements or filters must be replaced as frequently as the fluid filters, but at least once per year.

1.4.3. Model code (also order example)

BLT M 160 F 3 W 1. X

1.4.3.1 Complete filter

Filter type _____

BLT

Filter material _____

M (molecular strainer)

Size _____

160 (connection tube: steel; spin-on can: sheet metal)

Type of connection _____

Type	Filter size
F	●
S	●

F = flange connection

S = weld connection

Filtration rating in μm _____

3 = 3 μm absolute

Type of clogging indicator _____

W = no port for clogging indicator

Type code _____

1

Modification number _____

X the latest version is always supplied

1.4.3.2 Replacement element

0160 MU 003 M

Size _____

0160

Type _____

MU

Filtration rating in μm _____

003 3 μm absolute

Filter material _____

M molecular strainer

1.4.4. Dimensions

Flange model

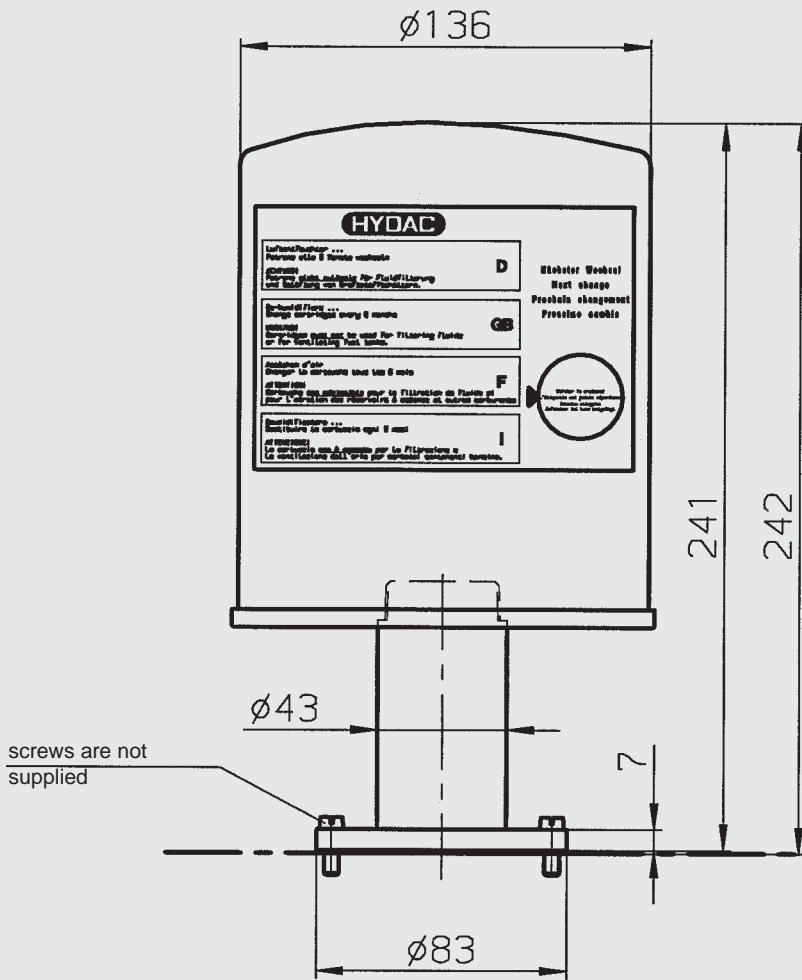

Weld model

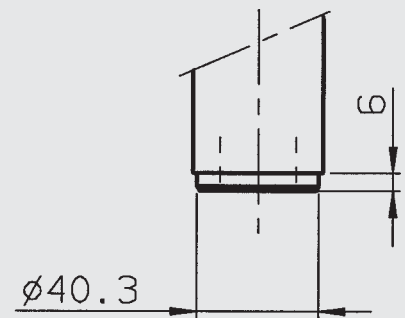

Interface to DIN 24557/part 2

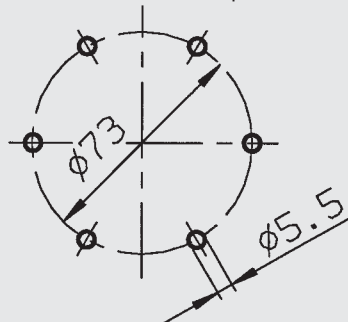

2. ADAPTORS

Filler adaptor -1/2-30-A.0 (318597)

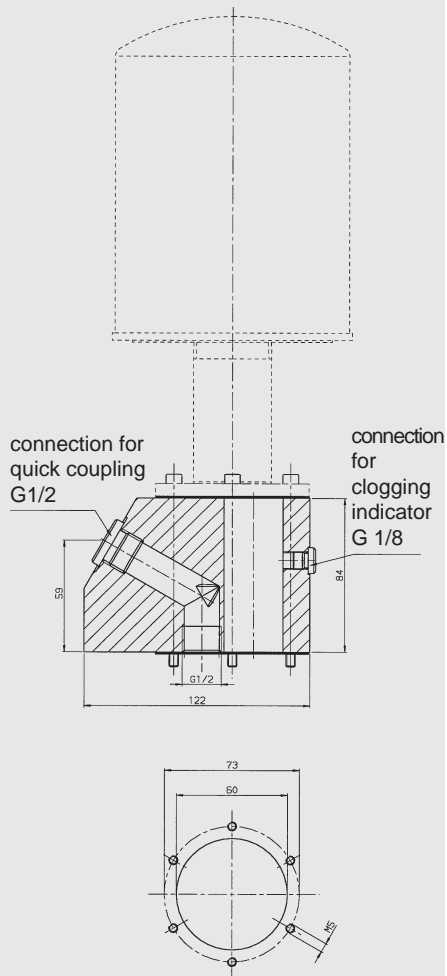

Interface to
DIN 24557/Part 2

Filler adaptor -1/2-W-0-W.0 (318596)

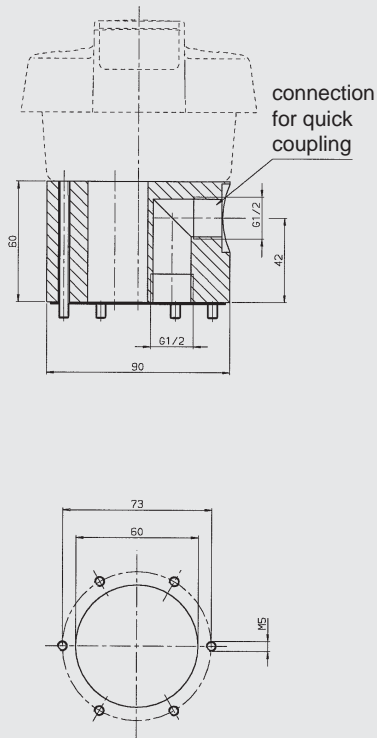

Interface to
DIN 24557/Part 2

3. GENERAL

3.1. AIR FILTER ELEMENTS

3.1.1. Single-pass filtration performance data for air filter elements

The following separation values were established under real-life simulated conditions. This means that the selected velocity of the flow against the filter mesh was 20 cm/s and the contamination added was 40 mg/m³ of ISO MTD test dust.

Filtration rating	Retention value d	For particle size	Filter material
3µm	d 80	0.74 µm	Paper
	d 100	2.64 µm	
10µm	d 80	1.49 µm	Paper
	d 100	9.56 µm	
10µm	d 80	0.25 µm	BN
	d 100	0.84 µm	
20µm	d 80	0.36 µm	BN
	d 100	1.21 µm	

The d 80 value refers to the particle size which is filtered out at a rate of 80% during the retention test. The particle size determined by this method is called the nominal filtration rating of the air filter. The d 100 value therefore refers to the particle size which is filtered out at a rate of 100% during the single-pass test. The particle size determined by this method is called the absolute filtration rating of the air filter.

Table of average dust concentrations in real life:

Urban regions with a low level of industry	3 - 7 mg/m ³ air
General mechanical engineering	9 - 23 mg/m ³ air
Construction industry (wheeled vehicles)	8 - 35 mg/m ³ air
Construction industry (caterpillar vehicles)	35 - 100 mg/m ³ air
Heavy industry	50 - 70 mg/m ³ air

3.1.2. Realistic contamination retention capacity of air filter elements

ISO MTD contamination retention quantity in g at $\Delta p = 0.05$ bar

Size	3µm	10µm	20µm
3	6.2	8.7	–
4	2.9	4.1	–
5	85.1	119.6	–
52	170.2	239.2	–
7	26.1	36.7	–
8	–	459.3	528.9
40	6.2	8.7	–
82	–	67.6	99.4
162	173.1	192.0	201.3

3.1.3. Air filter material

Material: phenolic resin impregnated paper or inorganic fibre

Note: None of the air filter elements can be cleaned!

4. FILTER SIZING

AIR FLOW RATE

ELF 3 .. / BF 3 .. / BL 40

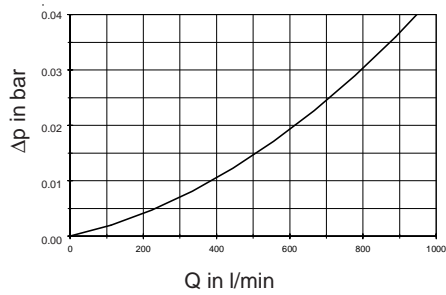

ELF 4 .. / BF 4 ..

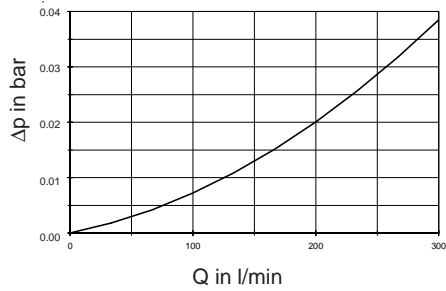

ELF 5 .. / BF 5 ..

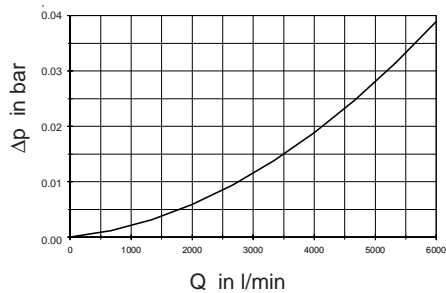

ELF 52 .. / BF 52 ..

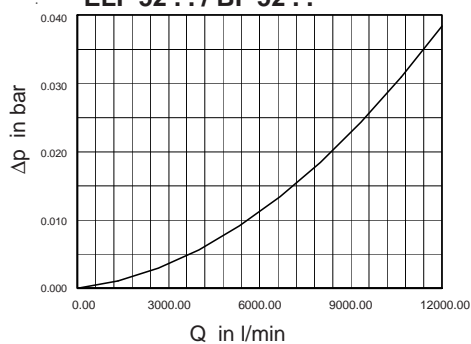

ELF 7 .. / BF 7 ..

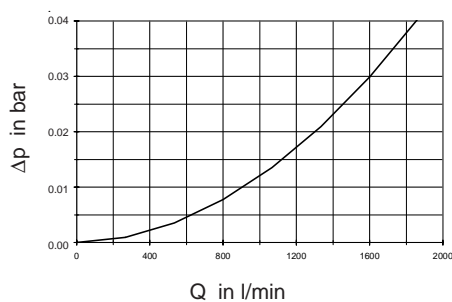

BF 8 ..

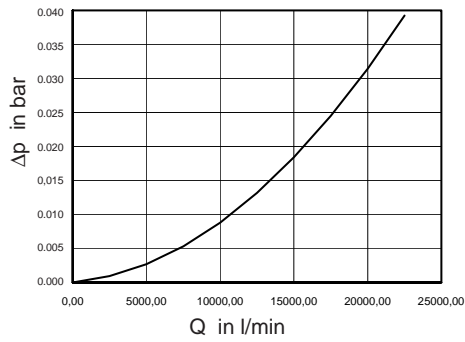

BL 82 ..



BL 162 ..

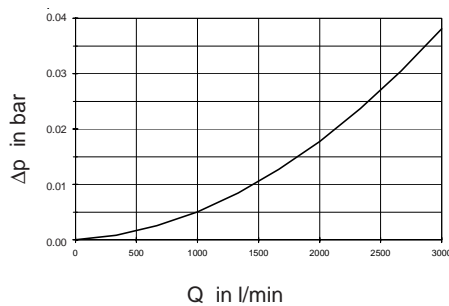

BLT 160 ..

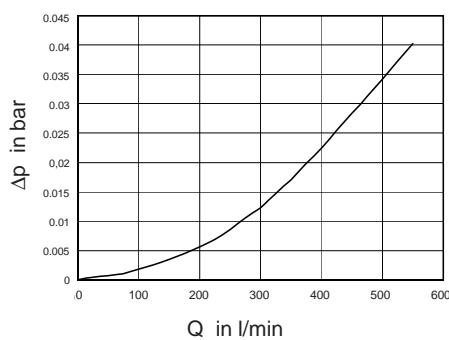

4.1 DIFFERENTIAL PRESSURE ACROSS BREATHER FILTER

The differential pressure (with clean element) for the various filter sizes is shown in the graphs under point 4.

4.1.1 Sizing guidelines

The rate at which contamination enters a hydraulic system can be considerably reduced by using efficient tank breather filtration.

Note:

Incorrectly sized tank breather filters can place additional strain on the system and reduce the service life of hydraulic filter elements.

For optimum sizing the following should therefore be observed:

- Filtration rating of air breather filter \leq filtration rating of hydraulic filter
- Only use air breather filters with an absolute retention rate ($d_{100} \leq x \mu\text{m}$; $x =$ given filtration rating)
- Max. permissible initial pressure loss: 0.01 bar (with a clean filter element and calculated air flow rate)
- Determination of the calculated air flow rate:

$$Q_A = f_5 \times Q_p$$

Q_A = air flow rate for sizing purposes in l_N/min

f_5 = factor for operating conditions

Q_p = max. flow rate of the hydraulic pump in l/min

Table of factor f_5

Operating conditions	Factor f_5
Low dust concentration; filter with clogging indicator; continuous monitoring of the filter	1 - 2
Average dust concentration; filter without clogging indicator; intermittent monitoring of the filter	3 - 6
High dust concentration; filter without clogging indicator; infrequent or no monitoring of the filter	7 - 10

5. DRYMICRON

(Breather / dryer)

5.1. TECHNICAL DESCRIPTION

5.1.1 Filter housing

Construction

Drymicron breather/dryers consist of a filter cartridge and the relevant threaded or flange adaptor.

Drymicron cartridges prevent contamination particles and water vapour from entering the fluid system. It is particularly important to protect rapidly biodegradable fluids from contaminating water vapour.

5.1.2 Filter elements

The replacement Drymicron breather/dryer cartridges consist of orange gel which once completely saturated cannot be regenerated. Two filter layers at the top and bottom of the silica gel prevent solid particles from entering the inside of the cartridge (filtration of particles > 2 µm). This ensures optimum humidity absorption.

To guarantee the performance of the protective filter layers, the entire cartridge has to be replaced.

5.1.3 Seals

Perbunan (NBR) on the bayonet adaptor; cardboard on the mounting flange

5.1.4 Special models

– On request

5.2. GENERAL

5.2.1 Temperature range

0 °C to 100 °C

5.2.2 Weight

BD 100 0.6 kg

BD 200 0.9 kg

BD 400 1.5 kg

Symbol

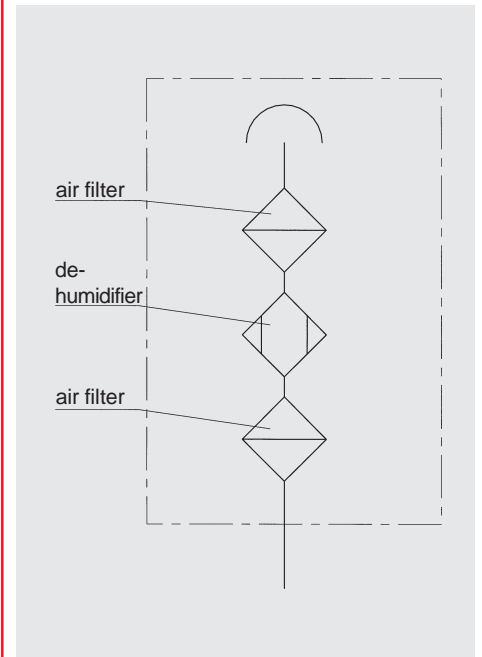

5.3. MODEL CODE (also order example)

5.3.1 Complete filter

BD 200 G 2 W 1. X

Filter type

BD

Size

100, 200, 400

Connection

B = bayonet connection

F = flange connection

G = threaded connection

Filtration

2 = 2 µm

Clogging indicator

W = no port for clogging indicator

Clogging indicator

Type code	Bayonet connection	Flange connection	Threaded connection
1	●	●*	G ³ / ₄
2	–	–	G1
3	–	–	1½-16UN

*according to DIN 24557 / part 2

Modification number

X = the latest version is always supplied

5.4. DIMENSIONS

5.4.1 Drymicron BD 100-400

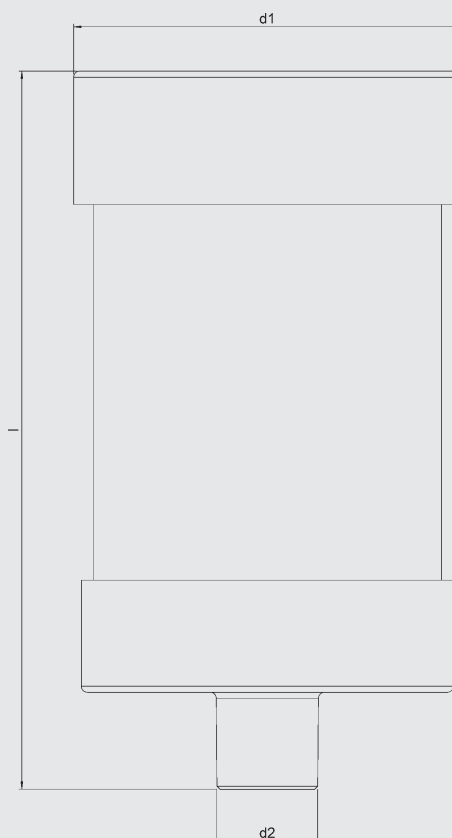

Type	d1	d2	l
BD 100	128	33.8	122
BD 200			160
BD 400			237

5.4.2 Adaptor

Bayonet connection

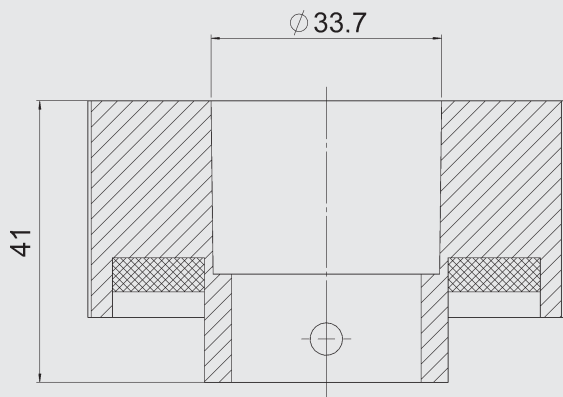

Threaded connection

G $\frac{3}{4}$

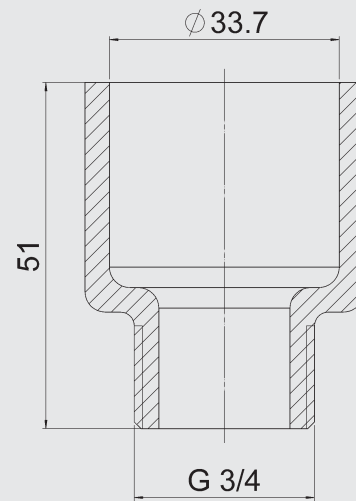

Flange connection

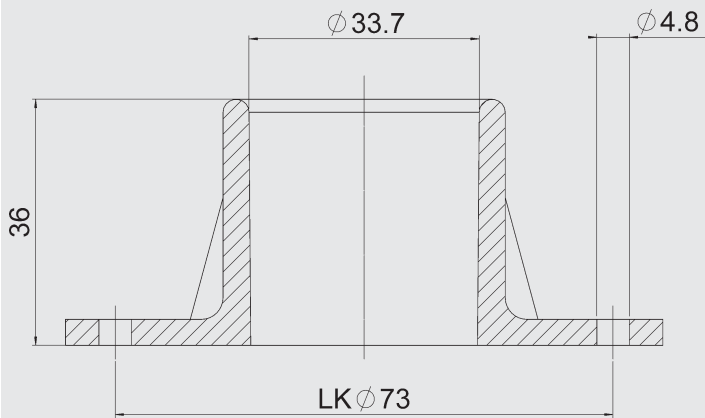

G 1

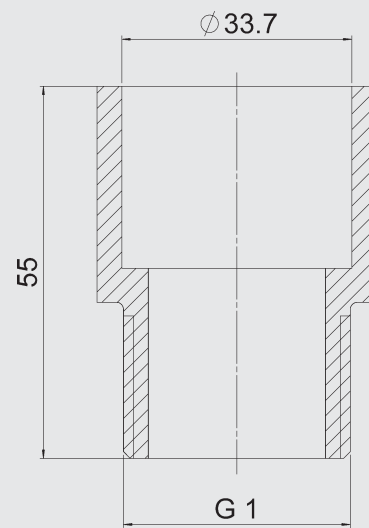

1 $\frac{1}{2}$ -16 UN

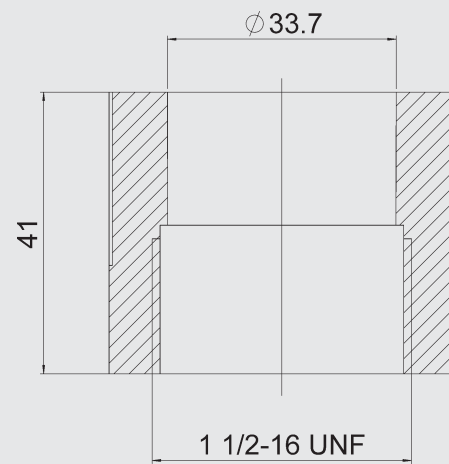

6. LU (DEHUMIDIFIER WITH BREATHER FILTER)

Dehumidifiers are designed to extract moisture from air entering the tank. The degree of water absorption is indicated by a change from orange (dry) to colourless (saturated). When used in conjunction with an air breather filter, solid particles are also extracted from the inflowing air. These dehumidifiers are especially recommended for systems that are operated in a very humid atmosphere.

6.1. TECHNICAL DESCRIPTION

6.1.1. Filter housing

Construction

The dehumidifiers consist of a transparent container with threaded end caps top and bottom which contains the silica gel.

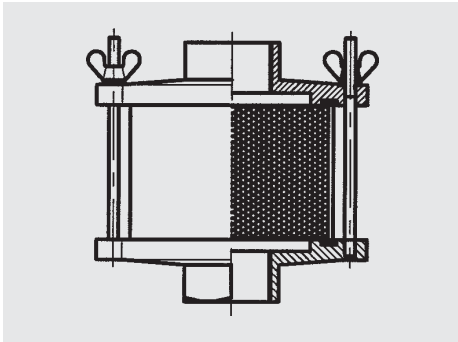

The dehumidifiers with protective filters are additionally fitted with a breather filter (BF) on top, which is intended to protect the silica gel from external particle contamination.

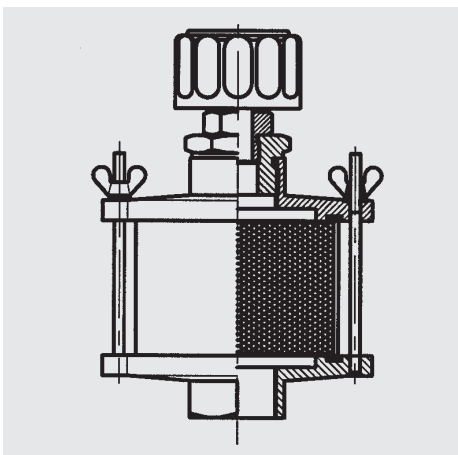

The dehumidifiers with tank breather filters are fitted with a breather filter positioned downstream of the dehumidifier. This breather filter has two check valves (RV); one of these protects the dehumidifier from oil or oil vapours which could condense on the silica gel; the other check valve releases to the tank any pressure resulting from fluid flowing backwards.

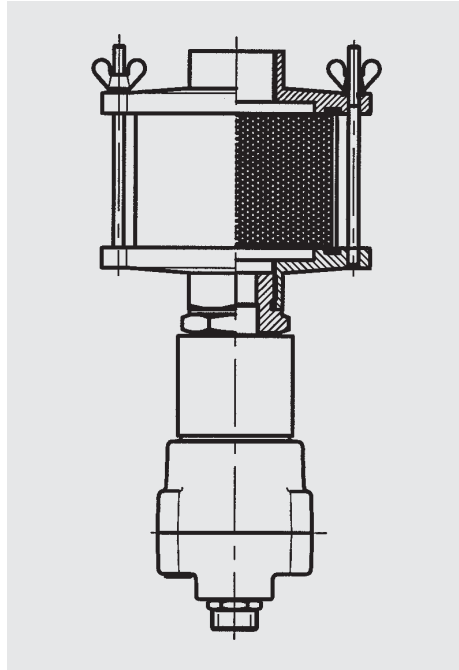

The dehumidifiers with tank breather filters and protective filters combine all functions.

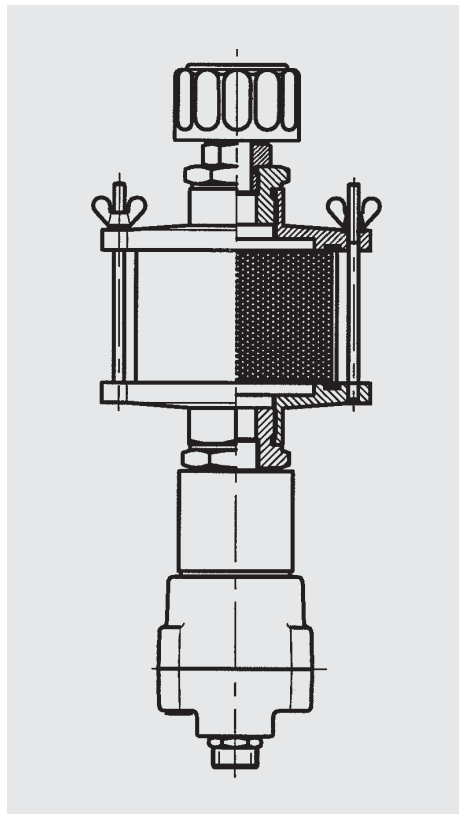

6.1.2. Filter elements

Hydac filter elements fulfil all ISO test criteria.

Reliable filter operation is only guaranteed for original Hydac filter elements.

The filter elements are made from phenolic resin impregnated paper and cannot therefore be cleaned.

Fluid compatibility

Suitable for use with mineral oils, lubrication oils, non-flam fluids and synthetic and rapidly biodegradable oils.

6.1.3. Seals

Perbunan (=NBR)

6.1.4. Special models and accessories

– On request

6.2. GENERAL

Temperature range

0 °C to +100 °C

Orange silica gel contents

LU 1	0.5 kg
LU 2	1.5 kg
LU 3	2.5 kg

Symbol

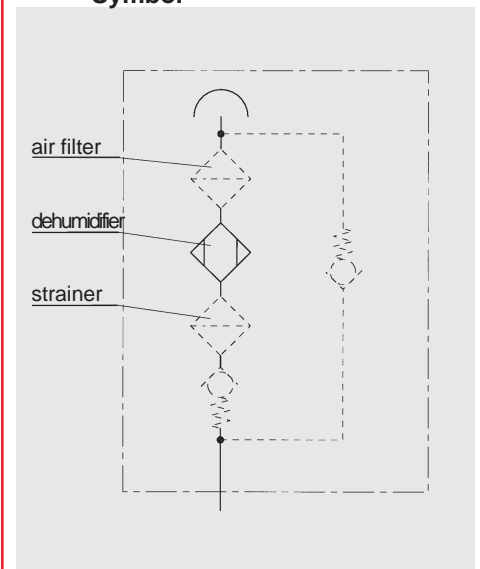

6.3. MODEL CODE (also order example)

LU BN/HC 1 GG 20 W 1. X /-310

6.3.1. Complete filter

Filter type

LU

Filter material

No details = without tank breather filter

BN/HC with tank breather filter (Betamicon®)

Size

1 with 0.5 kg silica gel

2 with 1.5 kg silica gel

3 with 2.5 kg silica gel

(material: dehumidifier = tie-bolts: stainless steel; end caps: aluminium;

connection components: zinc-plated steel

protective filter = steel, sheet steel or glass fibre reinforced synthetic material (depending on model)

breather filter = housing: aluminium; check valves: brass/stainless steel

Type of connection

GG threaded cap top and bottom

Filtration rating in µm

0 without tank breather filter

20 2µm absolute

Type of clogging indicator

W = without indicator port

Type code

1 with Plexiglass cylinder (gaskets in NBR)

2 with glass cylinder (gaskets in Viton)

Modification number

X the latest version is always supplied

Supplementary details

310 with protective filter, model BF3, 10µm

510 with protective filter, model BF5, 10µm

710 with protective filter, model BF7, 10µm

6.3.2. Replacement element for protective filter

0005 L 010 P

Size

0005

0007

Model

L for air filter element

Filtration rating in µm

003 3µm absolute

010 10µm absolute

Filter material

P paper (absolute filtration)

6.3.3. Replacement element for tank breather filter

0060 D 020 BN3HC

6.4. FILTER SIZING

6.4.1. Dehumidifier data

LU size	1	2	3
Orange silica gel	0.5 kg	1.5 kg	2.5 kg
Water retention capacity C_W at $T = 20\text{ }^\circ\text{C}$	30g	90g	150g
Max. flow rate Q_{max} at $T = 20\text{ }^\circ\text{C}$	14 l/min	42 l/min	70 l/min
Δp at Q_{max}	0.08 mbar	0.60 mbar	2.00 mbar

6.4.2. Sizing criteria

In order to ensure effective dehumidification under atmospheric pressure, the following must be observed:

max. permissible flow rate in the dehumidifier:

$$V_{\text{max}} = 0.5 \text{ m/sec}$$

minimum waiting time required:

$$t_{\text{min}} = 2.7 \text{ sec}$$

Since the great variety of conditions for dehumidification for hydraulic applications cannot be precisely covered mathematically, the calculation is based on a constant flow rate at 100% relative air humidity. Deviations from these figures can occur depending on the ambient conditions.

6.5. DIMENSIONS

6.5.1. Dehumidifier

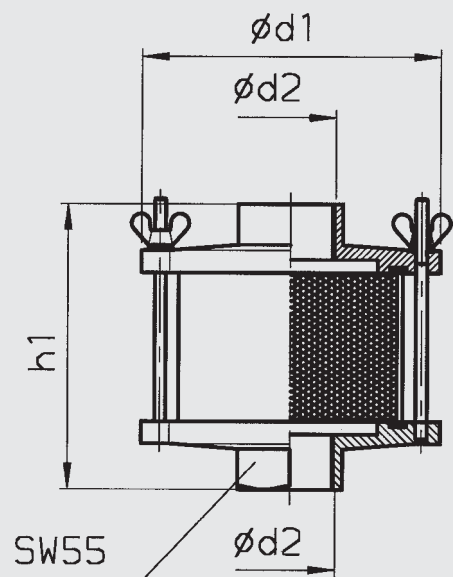

Type	d1	d2	h1
LU 1	160	G 1½	154
LU 2	160	G 1½	314
LU 3	160	G 1½	474

6.5.2. Dehumidifier with air breather filter

with BF 3

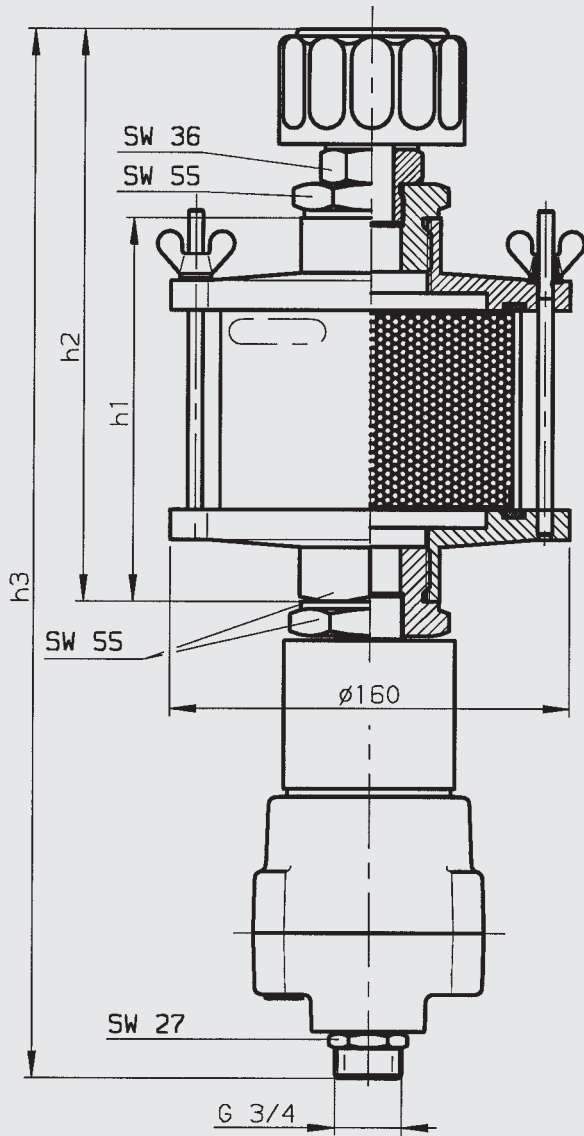

Type	h1	h2	h3
LU 1	154	231	425
LU 2	314	391	585
LU 3	474	551	745

with BF 5

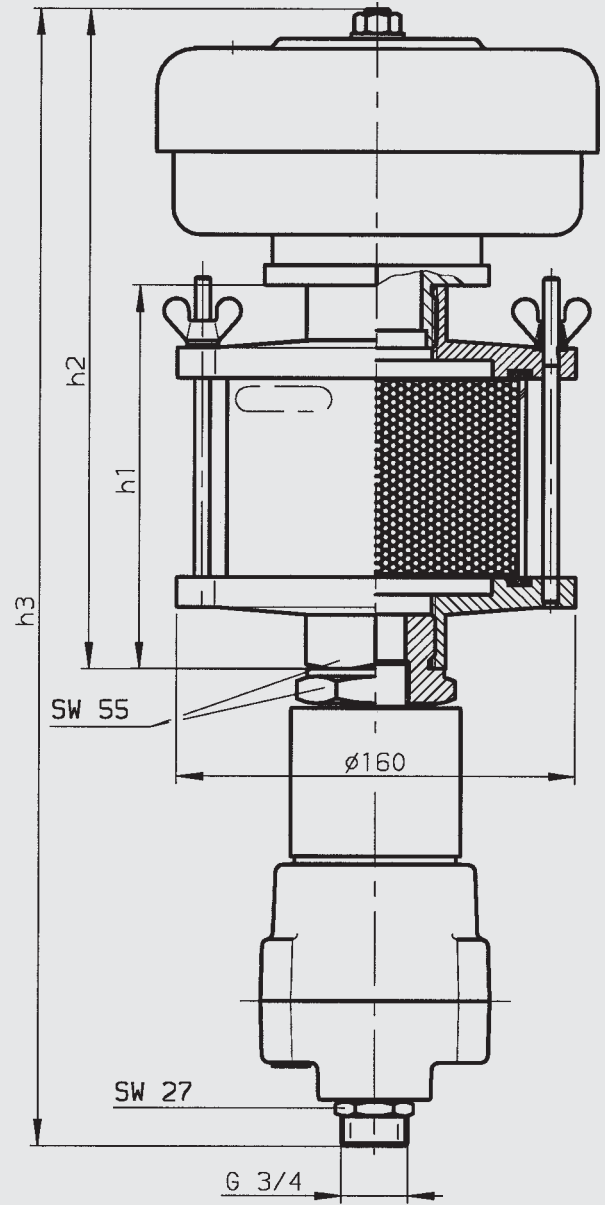

Type	h1	h2	h3
LU 1	154	265	459
LU 2	314	425	619
LU 3	474	585	779

6.5.3. Dehumidifier with air breather filter

with BF 7

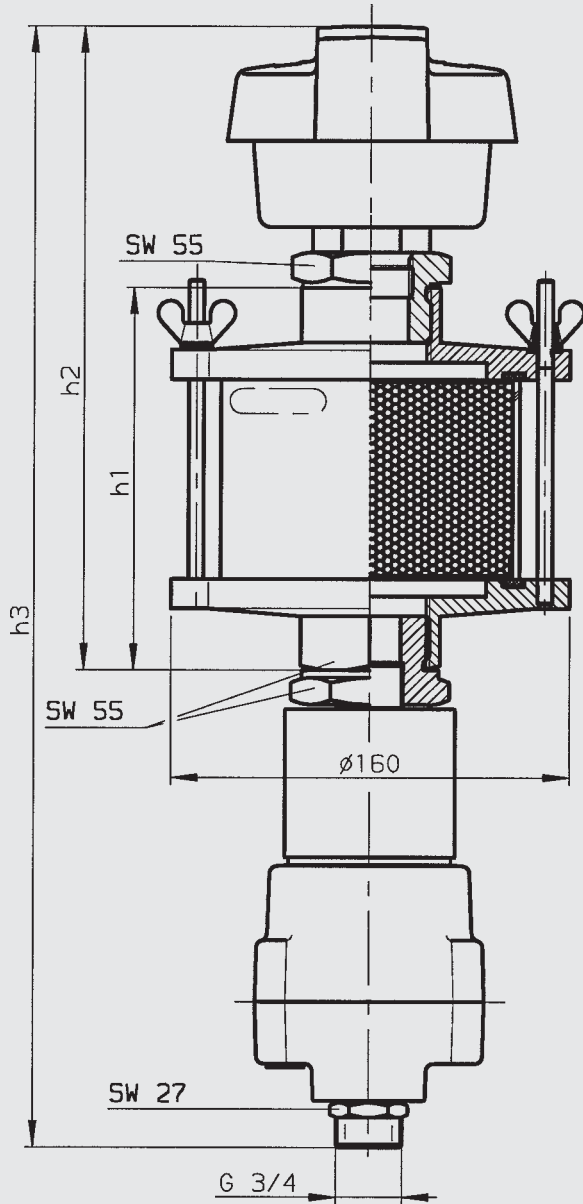

7. NOTE

The information in this brochure relates to the operating conditions and applications described.

For applications or operating conditions not described, please contact the relevant technical department.

Subject to technical modifications.

Type	h1	h2	h3
LU 1	154	259	453
LU 2	314	419	613
LU 3	474	579	773

